

 10 min	 x1	 x2
---	---	---

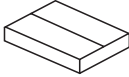

**A x1**



**B x4**

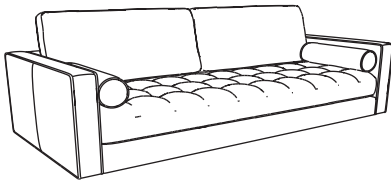

**C x1**

1

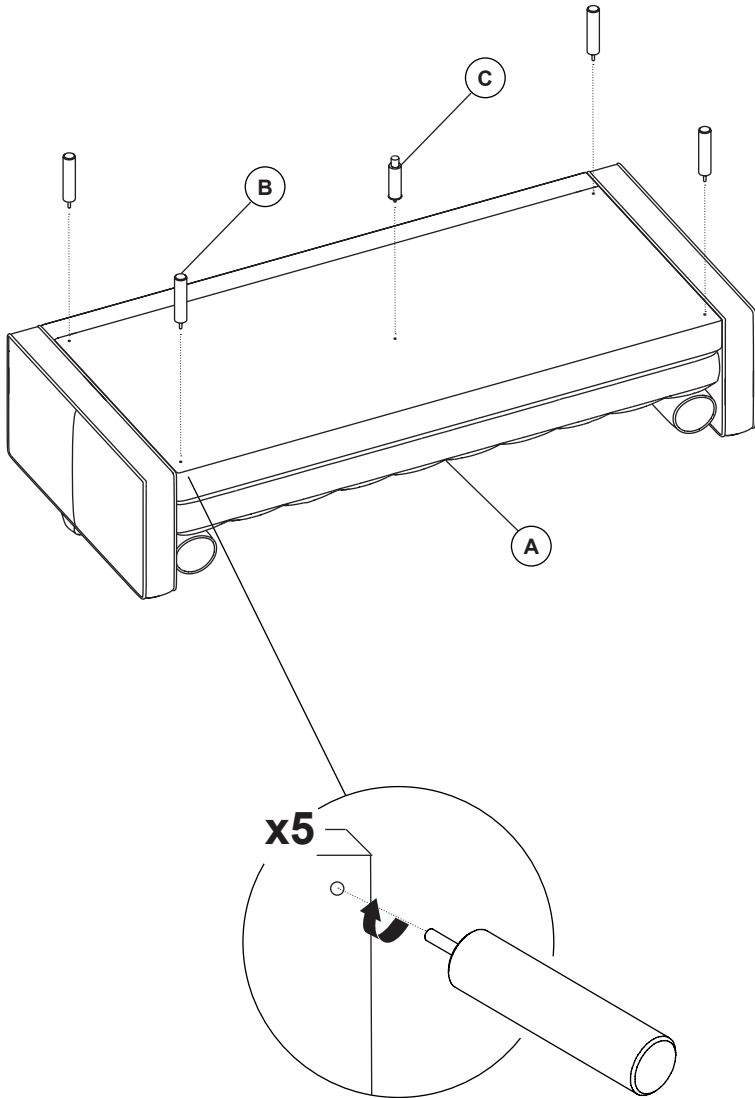

2

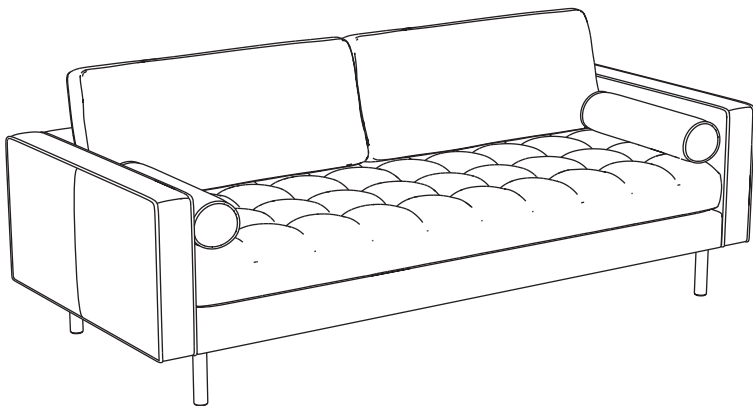
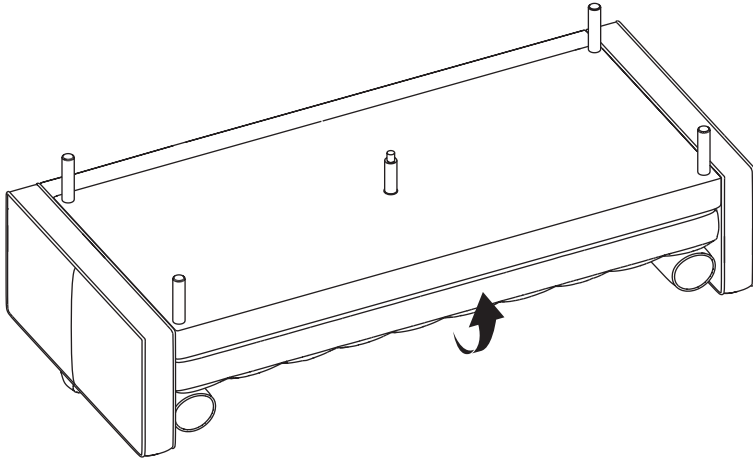

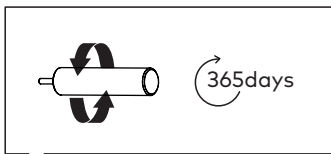
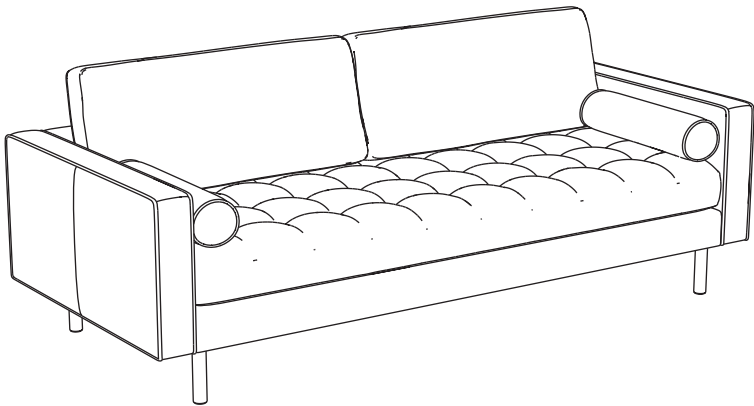





**THAT'S ALL FOLKS!**

Share your style!

**#KaveHome**

